



FT 18

Electric pallet truck 1800 Kg
High performance series / walkie model

- Flexible and manage several functions equally
- Ideal for supermarkets
- High handling capacity
- Powerful, low maintenance

DISTINGUISHING MARK

1.1	Manufacturer				F/FIL
1.2	Model designation				FT18
1.3	Drive unit				Electrics
1.4	Operator type				pedestrian
1.5	rated capacity	Q	lb.	kg	1800
1.6	Load center distance	c	in.	mm	600
1.7	Load distance	x	in.	mm	945
1.9	Wheelbase	y	in.	mm	1270

WEIGHT

2.1	Service weight (include battery)		lb.	kg	285
2.2	Axle loading, laden driving side/loading side		lb.	kg	770/1315
2.3	Axle loading, unladen driving side/loading side		lb.	kg	230/55

TYPES CHASSIS

3.1	Tyre type driving wheels/loading wheels				polyurethane/ polyurethane
3.2	Tyre size, driving wheels (diameter×width)		in.	mm	Φ230x75
3.3	Tyre size, loading wheels (diameter×width)		in.	mm	Φ74x88 / Φ80x60
3.4	Tyre size, caster wheels (diameter×width)		in.	mm	Φ85x48
3.5	Wheels, number driving , caster/loading (x=drive wheels)		in.	mm	1x+2/2 / 1x+2/4
3.6	Track width, front,driving side	b ₁₀	in.	mm	435
3.7	Track width,rear,loading side	b ₁₁	in.	mm	390/495/535

DIMENSIONS

4.4	Lift height		h ₃	in.	mm	115
4.9	Height drawbar in driving position min./max		h ₁₄	in.	mm	715 / 1200
4.15	Lowered height		h ₁₃	in.	mm	85
4.19	Overall length		l ₁	in.	mm	1625
4.20	Length to face of forks		l ₂	in.	mm	475
4.21	Overall width		b ₁ / b ₂	in.	mm	645
4.22	Fork dimensions		s/ e/ l	in.	mm	50x150x1150
4.25	Distance between fork-arms		b ₅	in.	mm	540/645/685
4.32	Ground clearance, center of wheelbase		m ₂	in.	mm	35
4.34.1	Aisle width for pallets 1000 × 1200 crossways		Ast	in.	mm	1720
4.34.2	Aisle width for pallets 800 × 1200 lengthways		Ast	in.	mm	1920
4.35	Turning radius		Wa	in.	mm	1465

PERFORMANCE DATA

5.1	Travel speed, laden/ unladen	km/ h	mph	km/h	5.5/6
5.2	Lifting speed, laden/ unladen		fpm	m/ s	0.051/ 0.060
5.3	Lowering speed, laden/ unladen		fpm	m/ s	0.032/ 0.039
5.8	Max gradeability, laden/unladen			%	6/16
5.10	Service brake type				Electromagnetic

ELECTRIC-ENGINE

6.1	Drive motor rating S2 60 min		hp	kW	1.1
6.2	Lift motor rating at S3 15%		hp	kW	0.84
6.3	The maximum allowed size battery		in.	mm	269x182x300
6.4	Battery voltage/nominal capacity K20		V/ Ah		2x 12/85
6.5	Battery weight		lb.	kg	25 x2

ADDITION DATA

8.1	Type of drive control				AC
10.5	Steering type				Mechanical
10.7	Sound pressure level at the driver's ear		dB (A)		74

1.The parameters in the table are of the standard model. For more information please contact us.
2.The parameters are subject to change without notice.

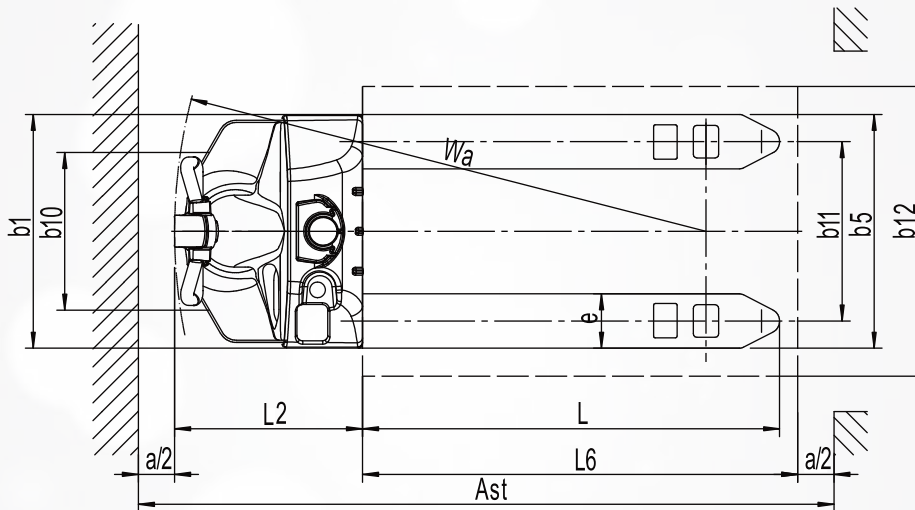
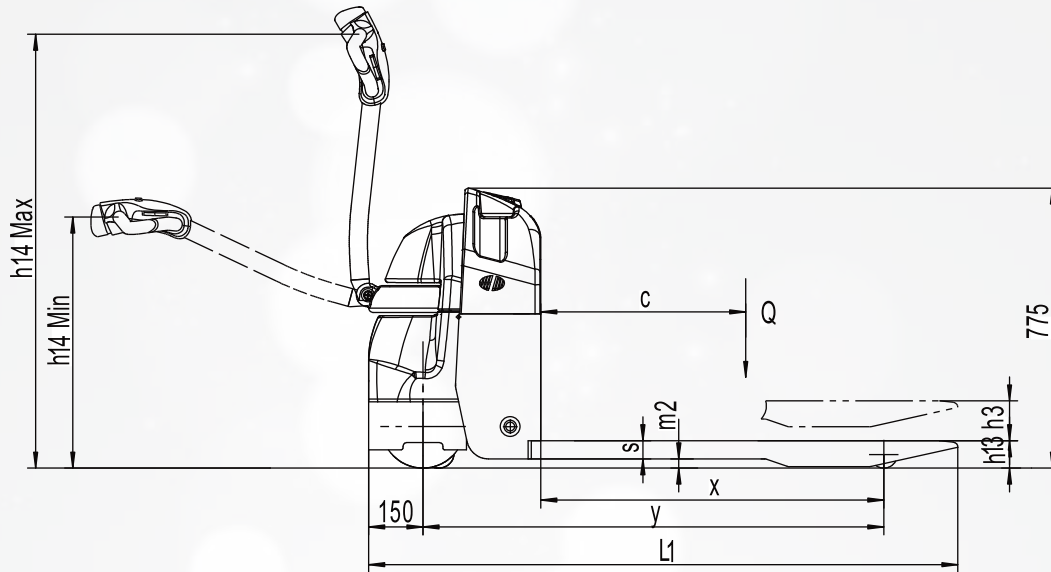

OPTION

Options	FT18
	850/915/1000/1150/1185/1220/1300/1450mm
	85mm
Driving wheel	•Rubber
Balance wheel	•
high capacity battery	•60AH/85AH/120AH
Cold storage	•
battery indicator with hour meter	•
water auto-filling system	•
Special backrest	•1220mm (48in)/1520mm (60in)



FT 18 CS

Electric Pallet Truck Cold Storage

The electric pallet truck FT 18 CS for refrigerated warehouses, blast freezers and other cold storage warehouses. Our Electric pallet truck FT 18 CS offers superior energy efficiency and never compromise on reliability and durability